

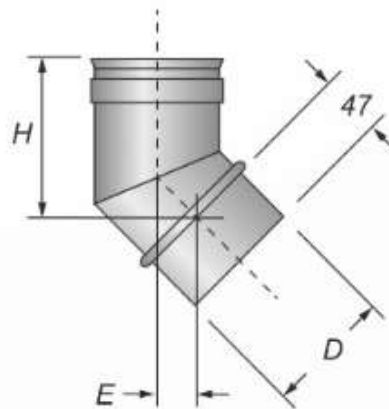

### CURVA 45°

La curva a 45° permette di effettuare spostamenti sia in verticale che in orizzontale.



D	H	E
80	123	31
100	129	34
110	132	35
120	136	37
130	139	38
140	142	39
150	146	41
160	149	42
180	155	45
200	162	48
220	168	50
250	178	54
300	194	61
350	210	68